

The Battery Operated Geri-Chair Scale Model FHD-133-II

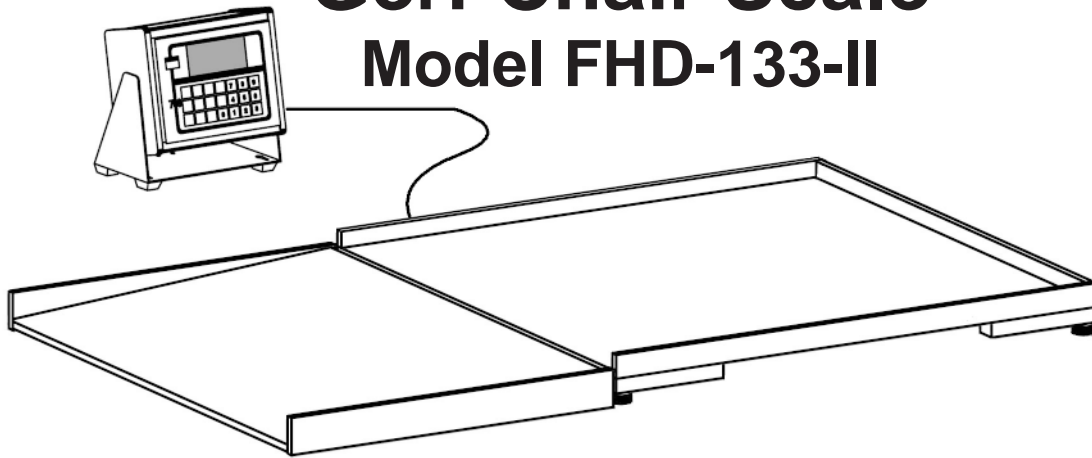

The battery operated Model FHD-133-II Geri-chair scale has a nonskid platform and ramp. The large platform accommodates walk-on patients, wheelchairs, or straight-legged chairs. This large capacity scale can be mounted flush with the floor if desired. The remote digital weight display includes .6" high LED readout with keypad tare and is suitable for desk or wall mounting.

SPECIFICATIONS

Capacity:	1,000 lb x .2 lb/450 kg x .1 kg
Display:	.6" LED with keypad tare
Power:	115 VAC
Platform:	36" x 36", smooth steel covered with black rubberized mat
Platform Height:	Adjustable from 2 3/4" to 3 1/4"
Ramp:	24" long (one ramp included)
Cable Length:	25'

48" x 48" base and ramp available for oversized wheelchairs.

Cardinal Scale reserves the right to improve, enhance or modify features and specifications without prior notice.